

## Application of Eluent Generation for Trace Anion Analysis of Borated Waters

Boric acid is used in pressurized water reactor (PWR) power plants to control the nuclear reaction, because boron is a good neutron absorber. In PWR plants, measuring anionic contaminants in borated waters is an important part of corrosion monitoring. The presence of low- $\mu\text{g/L}$  (ppb) concentrations of chloride and sulfate can make the stainless steel components of a power plant, such as steam generators, boiler tubes, condenser tubes, and turbine blades, susceptible to stress-induced corrosion cracking.<sup>1</sup> Therefore, monitoring the presence of these anions is important. A reliable method is needed to determine anionic contamination at trace levels in borated waters.

Anions in borated waters are currently determined using ion chromatography (IC) with a sodium tetraborate eluent. This approach has several disadvantages. Preparing bottled eluents is labor intensive and operator dependent, leading to inconsistent results. Making a tetraborate eluent manually from tetraborate salts is problematic, particularly when using nonhydrated salts. When running tetraborate gradients, the concentration of the suppressed product—boric acid—increases with the gradient, leading to baseline shifts. Using boric acid and sodium hydroxide to prepare a tetraborate eluent is another approach, however contamination from carbonate causes a large baseline shift during the gradient that makes peak integration difficult.

Recently, a new automated method disclosed how to prepare tetraborate eluents using an EG50 Eluent Generator in conjunction with a boric acid eluent.<sup>2</sup> In this approach, the boric acid concentration is held constant while varying the potassium hydroxide concentration to create a gradient. The eluent generator can generate potassium hydroxide eluents that are free of carbonate contamination. Carbonate-free eluents result in consistent background conductivity and provide consistent peak response. This method minimizes baseline shifts during gradients and results in more reliable peak area integration. This application note describes a rapid, high-volume, direct-injection technique that uses an IonPac® AS14 2-mm analytical column. Common anions such as fluoride, chloride, nitrate, phosphate, and sulfate can be determined at levels below 1  $\mu\text{g/L}$  (ppb) in borated waters with up to 7500 mg/L boron in less than 30 min.

This method is also applicable for use with standard-bore (4-mm) chromatography by using a standard-bore GP50 pump, 4-mm AS14 column, and 4-mm ASRS® at a flow rate of 1.5 mL/min. A 1-mL loop with a standard bore configuration will have one quarter the peak response compared to using a microbore system.

## EQUIPMENT

Dionex ICS-2500 IC system consisting of:

- GS50 Gradient Pump with vacuum degas
- CD25A Conductivity Detector with DS-3
- EG50 Eluent Generator with EGC II KOH Cartridge, P/N 060585

LC30 Chromatography Enclosure equipped with Rheodyne Model 9126 injector PEEK, rear loading (P/N 057001)

AS40 Autosampler

Chromeleon® Chromatography Workstation

Columns: IonPac AS14 Analytical, 2-mm i.d. (P/N 046129)  
IonPac AG14 Guard, 2-mm i.d. (P/N 046138)

Suppressor: ASRS ULTRA II, 2 mm (P/N 061562)

300 cm of green 0.75-mm (0.030-in.) PEEK tubing (P/N 052305) to make a 1000- $\mu$ L sample loop

Suppression External Water Installation Kit includes 25 psi regulator and a 4-L water reservoir (P/N 038018)

Upchurch Plastic Tubing Cutter (Dionex P/N 49584 or Upchurch P/N A-327)

Filter unit, 0.2  $\mu$ m, nylon (Nalgene 90-mm Media-Plus), (Nalge Nunc International, P/N 164-0020 or equivalent)

Ion chromatography Acrodisc® filters, 13 mm, 0.2- $\mu$ m pore size (optional) (Gelman Sciences, P/N 4483)

## REAGENTS, STANDARDS, AND SAMPLES

Deionized water, Type I reagent-grade, 18 M $\Omega$ -cm resistance

Boric acid, J. T. Baker reagent-grade

Sodium borate, tetrahydrate, J. T. Baker reagent-grade

Fluoride standard 1000 mg/L, 100 mL (Dionex P/N 037158)

Chloride standard 1000 mg/L, 100 mL (Dionex P/N 037159)

Sulfate standard 1000 mg/L, 100 mL (Dionex P/N 037160)

Nitrate standard 1000 mg/L, 100 mL (Dionex P/N 056497)

Phosphate standard 1000 mg/L, 100 mL (ULTRA Scientific, VWR P/N ULICC-005)

ACS reagent-grade materials for preparing anion standards (VWR or others), optional

## 50 mM Boric Acid Eluent

Weigh 3.09 g of boric acid. Carefully add this amount to a 1-L volumetric flask containing about 500 mL of deionized water (with a specific resistance of 18 M $\Omega$ -cm or greater). Dilute to the 1-L mark and mix thoroughly. Use a stir bar or ultrasonic bath to ensure that the boric acid is completely dissolved. Filter the solution through a 0.2- $\mu$ m nylon filter unit. Transfer this solution to an eluent container and vacuum degas for 5 min.

## Anion Standard Solutions (1000 mg/L)

Several of the analytes of interest are available as 1000-mg/L anion standard solutions from Dionex or other commercial sources. When commercial standards are unavailable, 1000-mg/L standards can be prepared by dissolving the appropriate amounts of the corresponding mass for the target analytes in 1000 mL of deionized water according to Table 1. We recommend making a 100-mL final volume of 1000-mg/L stock standards in 125-mL high-density polyethylene (HDPE) containers. Concentrated standards are stable for at least one month when stored at 4 °C.

Table 1. Amounts Used to Prepare 1 L of 1000-mg/L Anion Standards

Anion	Compound	Mass (g)
Fluoride	Sodium fluoride (NaF)	2.210
Chloride	Sodium chloride (NaCl)	1.648
Nitrate	Sodium nitrate (NaNO <sub>3</sub> )	1.371
Sulfate	Sodium sulfate (Na <sub>2</sub> SO <sub>4</sub> )	1.479
Phosphate	Potassium phosphate, monobasic (KH <sub>2</sub> PO <sub>4</sub> )	1.433

## CALIBRATION

### Working Standard Solutions

The anion concentrations in borated water samples were determined using external standards prepared in deionized water. Composite working standards were prepared by diluting appropriate volumes of the 1000-mg/L stock standards with deionized water. Working standards containing <100 mg/L anions should be prepared daily.

## ATC-HC Regeneration Solution

### 100 mM Sodium Borate

Thoroughly dissolve 38.14 sodium borate, tetrahydrate (MW 381.42 g/mole) in 700 mL degassed deionized water (with a specific resistance of 18 M $\Omega$ -cm or greater) in a 1-L volumetric flask. Dilute to a final volume of 1000 mL.

### CONDITIONS

Columns:	IonPac AS14 Analytical, 2-mm i.d. IonPac AG14 Guard, 2-mm i.d.
Eluent:	50 mM boric acid titrated with potassium hydroxide from an EG50 Eluent Generator
Temperature:	30 °C
Gradient:	4.0 mM KOH from 0–6.0 min with 50 mM boric acid 4.0 to 30.0 mM KOH from 6–18 min with 50 mM boric acid
Flow Rate:	0.38 mL/min
Detection:	Suppressed conductivity
Suppressor:	ASRS ULTRA II, 2 mm, AutoSuppression <sup>®</sup> , external water mode
Suppressor current:	38–46 mA
Expected Background	
Conductivity:	3 $\mu$ S (30 mM potassium hydroxide/50 mM boric acid)
Recommended System	
Backpressure:	15.2–16.6 MPa (2200–2400 psi)

### SAMPLE LOADING

Load the sample into the sample loop with an AS40 Autosampler using the 5-mL vials. For analysis of samples containing target anions at  $\mu$ g/L concentration levels, the probability of contamination during sample collection and storage is high. Sample and standard containers, as well as autosampler vials and caps, should be rinsed with deionized water prior to use. *Use only AS40 sample vial caps without filters when performing low-level analyses.*

Samples that contain high amounts of particulate matter should be filtered with filters that will not contribute significant amounts of the analytes of interest. For this work, Gelman Ion Chromatography Acrodisc filters were used.

### Loading Samples in the Autosampler Vials for Routine Analysis

1. Rinse the vials and caps 3–5 times with DI water.
2. Fill the 5-mL vial with the standard, sample, or blank.
3. Insert the cap into the vial with the insertion tool (Dionex P/N 037987) and load into the sample cassette.

### Loading Samples in the Autosampler Vials for Trace Analysis

1. Rinse the vials and caps 3–5 times with DI water.
2. Place the vials and caps in a large, precleaned container and soak for 4 h in DI water.
3. Drain or empty the container and refill it with DI water. Soak the caps and vials for an additional 24 h before use.
4. Fill the 5-mL vial with the standard, sample, or blank.
5. Insert the cap into the vial with the insertion tool (Dionex P/N 037987) and load into the sample cassette.

### Pump Program Method

Time (min)	Flow (mL/min)	50 mM Boric Acid %	Valve	EG50 Conc (mM)	Comments
–7.00	0.38	100	Load	4.0	4.0 mM KOH
–2.4	0.38	100	Load	4.0	Load Loop, AS40 on
–0.1	0.38	100	Load	4.0	AS40 off
0.00	0.38	100	Inject	4.0	Inject, 4.0 mM
6.00	0.38	100	Inject	4.0	Begin gradient to 30 mM KOH
18.0	0.38	100	Inject	30.0	30 mM KOH
30.0	0.38	100	Load	30.0	30 mM KOH

### SYSTEM PREPARATION AND SETUP

This section describes the procedure for the initial installation and start-up of the ASRS ULTRA, ATC-HC, and EluGen<sup>®</sup> cartridge. Prepare the ASRS for use by hydrating the eluent chamber and regen chamber with deionized water. Wait at least 20 min before pumping eluent through the eluent chamber. (For more information on ASRS operation, consult the *Quickstart Instructions for the ASRS ULTRA*, Document No. 031368.)

Prepare the ATC-HC by rinsing with 100 mL of 100 mM tetraborate at 2.0 mL/min. This can be done off-line without the GS50 by pressurizing an eluent bottle with helium at 34.5 kPa (5 psi). Then rinse the ATC with boric acid at 2.0 mL/min for 20 min. Install the EGC II KOH EluGen cartridge according to the instructions in the *Operator's Manual for the EG50 Eluent Generator System* (Document No. 031908). Place the ATC-HC between the GS50 outlet and the EGC II KOH cartridge inlet as shown in Figure 1.

Configure the pressurized water reservoir as shown in Section 3.4, "Plumbing for the AutoSuppression External Water Mode Operation" of the *Product Manual for the Anion Self-Regenerating Suppressor ULTRA II* (Document No. 031956). Fill the reservoir with deionized water with a specific resistance of 18 M $\Omega$ -cm or greater. Adjust the reservoir pressure from 0 to 172 kPa (0 to 25 psi) to deliver external water regenerant of 5–7 mL/min before applying current. Ensure that the reservoir cap is sealed tightly. After applying the current, the flow rate will drop due to gas formation in the regenerant.

Make a 1000- $\mu$ L sample loop by cutting a 220-cm portion of 0.030-in. (0.75-mm) i.d. PEEK tubing. In cases where a loop or tubing with a different internal diameter is desired, refer to Table 2 to calculate the length needed. The volume of a loop can be verified by measuring the weight difference between the sample loop filled with deionized water and the dry, empty loop. The inside diameter of tubing varies by as much as 20% (e.g., 0.010  $\pm$  0.002 in.). For example a 250- $\mu$ L loop prepared with 0.030-in. i.d. PEEK tubing had a dry weight of 12.8327 g and weighed 13.0953 g filled with water. This weight difference and a repeat measurement suggest the loop is a 262- $\mu$ L loop. Connect the columns and suppressor in the IC system by using 0.005-in. (0.125-mm) tubing. Keep the lengths of connecting tubing as short as possible to minimize system void volume, which ensures efficient 2-mm column operation. Carefully use a plastic tubing cutter and make sure that the surfaces of the tubing cuts have straight and smooth surfaces. Irregularity on the surface of a tubing end can result in unwanted dead volume.

Turn flow on the gradient pump to begin the flow of eluent through the system. If the system backpressure is below 14 MPa (2000 psi), then a portion of the yellow PEEK 0.003-in. (0.075-mm) tubing should be added between the outlet of the degas assembly in the EG50

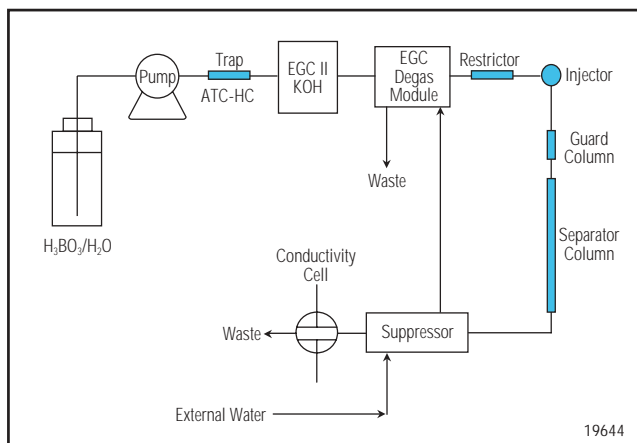

**Figure 1.** System configuration with the EG50 using boric acid eluent.

**Table 2. Volume Per Unit Length for Various Tubing Internal Diameters**

Material	Color	Internal Diameter (Inches)	Internal Diameter (mm)	Estimated Volume ( $\mu$ L/cm)
PEEK	Red	0.005	0.125	0.126
PEEK	Black	0.010	0.250	0.506
PEEK	Orange	0.020	0.500	2.022
PEEK	Green	0.030	0.750	4.550

and the inlet of the injection valve. Confirm that there are no leaks in the chromatographic pathway. For more information consult the *Operator's Manual for the EG50 Eluent Generator System* (Document No. 031908). Turn on the EG50 to deliver 30 mM KOH using Chromeleon and allow the background conductivity to reach a steady value.

## RESULTS AND DISCUSSION

The IonPac AS14 column provides the best selectivity for fluoride, chloride, nitrate, sulfate, and phosphate using a borate eluent. Fluoride is well resolved from the water dip and free of interference from weakly retained organic acids such as glycolate, acetate, and formate. The best separation of the target analytes was achieved with a gradient from 4 to 30 mM potassium hydroxide using 50 mM boric acid. The IonPac AS14 2-mm column (with a capacity of 65  $\mu$ eq/column) was selected because it has more than three times the capacity of the AS4A-SC column (20  $\mu$ eq/column capacity). Due to the high capacity, the AS14 can tolerate larger sample volumes by direct injection.

The microbore format, chosen for the analytical columns and suppressor, has several advantages for trace-level analysis, including a fourfold increase in mass sensitivity for the microbore (2-mm) over the standard-bore (4-mm) format with no change in concentration sensitivity. The increased mass sensitivity allows smaller sample volumes to be injected. The microbore format also uses less eluent and produces less eluent waste.

The ASRS ULTRA II provides low background and noise and facilitates low detection limits for the target anions. The DS-3 conductivity cell minimizes the effects of temperature-induced baseline drift. Separations were performed at 30 °C. A high-capacity anion trap column (ATC-HC) (Dionex P/N 059604) in the borate form was used to trap anionic contaminants in the boric acid eluent. The ATC-HC is placed between the outlet of the gradient pump and the inlet of the EluGen cartridge. The ATC-HC requires periodic regeneration with 100 mM sodium borate. Do not use a Continuously Regenerated Trap Column (CR-ATC) for this application, because it would remove anionic compounds—including borate ions—from the boric acid eluent.

The EG50 Eluent Generator enhances IC performance for the determination of anions at trace levels.<sup>3</sup> In this application, the EG50 was used to electrolytically produce high-purity, carbonate-free KOH eluents with boric acid as the carrier stream. Gradient separations with carbonate-free hydroxide eluents are highly precise and have negligible baseline shifts and lower background conductivity. Because the present method uses a constant stream of boric acid, all the benefits of electrolytically generated hydroxide eluents are realized, including better retention time reproducibility and improved signal-to-noise ratios.

The optimized gradient method for this application was quickly developed using the EG50 Eluent Generator. The EG50 was programmed with a number of isocratic methods and linear gradient eluent methods to evaluate a variety of eluent conditions. Without the EG50, it would have been necessary to proportion from a manually prepared eluent to achieve different gradient conditions.

The tetraborate eluent is made by a chemical reaction of boric acid with potassium hydroxide according to the following reaction:

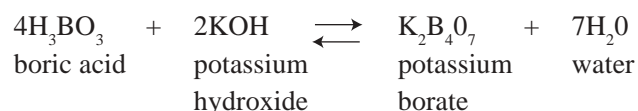

The 50 mM boric acid eluent is “titrated” with the potassium hydroxide generated in-line through the eluent generator. Four moles of boric acid react with two moles of potassium hydroxide to form one mole of tetraborate. For example, 8 mM boric acid is titrated with 4 mM potassium hydroxide to form 2 mM tetraborate.

By making the tetraborate eluent in-line with the EG50, carbonate is not mixed into the solution and therefore the chromatography is improved. Figure 1 illustrates how this eluent is made on-line. This technique has several advantages. The eluent strength can be adjusted by the on-line addition of potassium hydroxide. The background is maintained at the same level during gradient runs, because the boric acid concentration is held constant during the run.

### Method Performance

Figure 2 shows separation of a trace anion standard prepared in deionized water using the EG50 with the boric acid method. The large system void corresponds to the time required for the 1-mL sample to pass through the chromatographic system. The method began with an initial eluent concentration of 4 mM potassium hydroxide/50 mM boric acid to elute weakly retained ions.

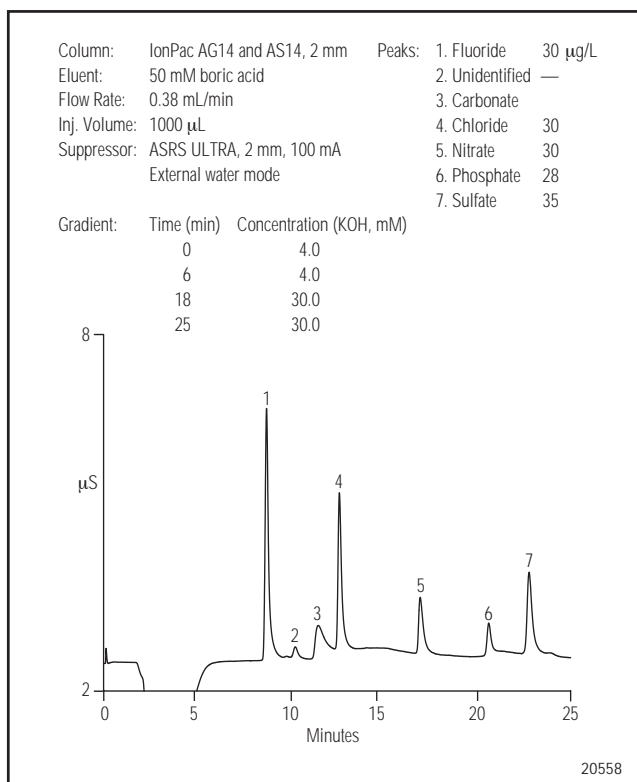

Figure 2. Trace anion standard in deionized water.

Fluoride is well resolved from the system void and resolved from the organic acids (glycolate, acetate, and formate) under these conditions. Depending on the amount of carbonate present in the sample, chloride may coelute with carbonate. Degassing the sample may minimize the presence of carbonate. The eluent concentration in this method increases from 4 to 30 mM potassium hydroxide in 12 min to elute stronger retained anions such as nitrate, phosphate, and sulfate. The pump program returns to a 4 mM potassium hydroxide/50 mM boric acid eluent to equilibrate for 7 min prior to the next injection.

This method is applicable to high-purity power plant waters containing up to 7500 mg/L boron as boric acid. Figure 3 shows an analysis of 2000-mg/L boron containing trace levels of anionic contamination. The large borate matrix peak beginning at 2 min returns to baseline before the first analytes of interest elute. No significant difference in peak efficiencies or retention times is observed compared to the standard prepared in deionized water. Chloride can elute on the downward slope of the carbonate peak, complicating integration. However, by using the “Maximum Rider Ratio” command in the Chromeleon chromatography software this peak can be reproducibly integrated as a rider on the slope of the carbonate peak.

To start trace-level analysis, first establish a blank. You can easily perform this task by injecting high-purity deionized water as a sample, using the same set of containers, pipetting devices, and so forth. A baseline anion concentration is established above which reliable quantification can be made. Make several replicate injections to establish a precise reading. Figure 4 shows a representative blank (from a typical laboratory point-of-use deionization system). It is not uncommon to have trace levels of chloride, nitrate, and sulfate from a typical laboratory point-of-use deionized water unit. Figure 5 shows a representative system blank. The data for the system blank were collected without a sample injection. Accomplish this action by using Chromeleon to select “Blank” as the “Sample Type” (explained in the help section under “Blank run sample”). No peaks were detected in the system blank, confirming that no significant anionic contaminants were present in the boric acid and the trap column is functioning properly.

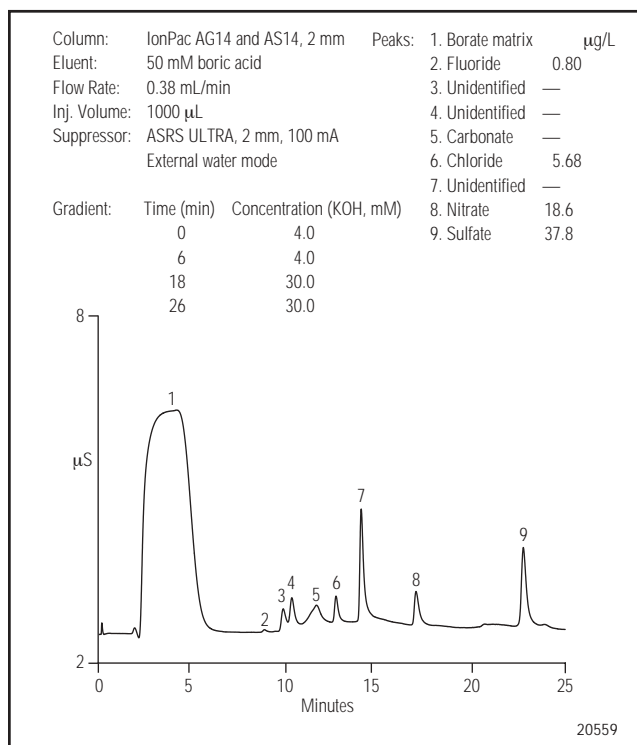

Figure 3. Trace anions in 2000 mg/L boron.

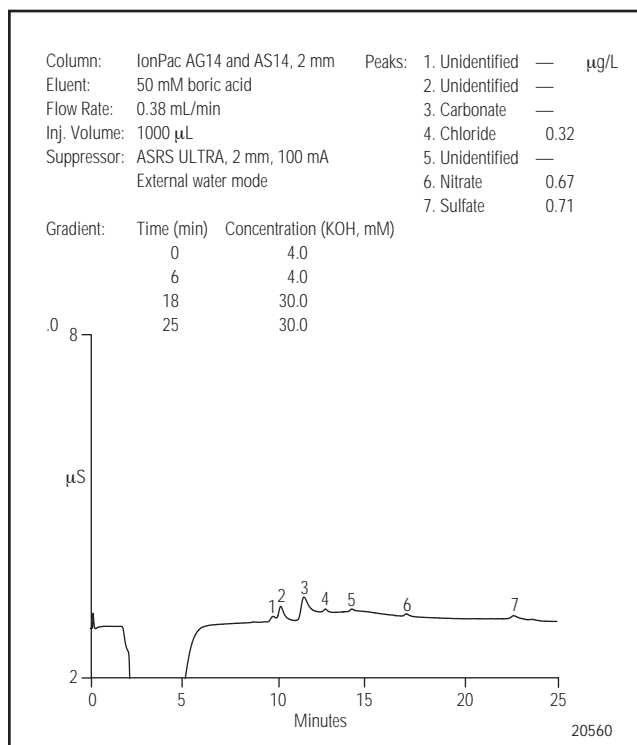

Figure 4. Representative deionized water blank.

The total baseline shift between the weak and strong eluent concentration in the separation presented in this application note would typically be 2  $\mu\text{S}$  with a manually prepared tetraborate eluent. The EG50-based method reduces the baseline shift to less than 0.1  $\mu\text{S}$ . The ATC-HC anion trap column traps anionic contaminants in the boric acid eluent. This trap column should be periodically regenerated by conditioning it with at least 100 mL of 100 mM sodium tetraborate solution. The frequency of trap column regeneration depends on the level of contamination in the 50 mM boric acid eluent.

For the best performance at trace levels, baseline noise must be kept to a minimum. A system for trace analysis typically requires about 1 h from start-up to establish a stable background conductivity. For this reason, it is best to keep the system running continuously. Ensure that you have an adequate supply of the eluents, external water, and waste containers to allow the system to run unattended.

The ICS-2500 instrumentation and Chromeleon software provide the analyst with the ability to monitor baseline noise. In a representative 1.0-min section, an equilibrated system in good working order should be able to deliver a noise reading of less than 5 nS peak to peak. In the diagnostic menu under “Pressure statistics”, the GS50 Gradient Pump displays the measured pressure from the pressure transducer. In a 1-min segment, the pump pressure reading difference should be less than 138 kPa (20 psi).

Calibration curves were obtained using anion standards prepared in deionized water. Three replicate injections were used at spikes of 1, 3, 10, and 30 ppb for fluoride, chloride, nitrate, sulfate, and phosphate in the matrix. Results for the anions of interest yielded a linear response with coefficients of determination ( $r^2$ ) greater than 0.997. Table 3 summarizes the method detection limits (MDLs) for the target analytes calculated based on three times the signal-to-noise ratio. Remember that the lowest quantifiable analyte concentration is generally three to five times greater than the lowest detectable concentration.

### PRECAUTIONS

The deionized water used for preparing rinse solution, eluent, and standards should be free of measurable levels of ionic impurities, organics, microorganisms, and particulate matter larger than 0.2  $\mu\text{m}$ . Soak containers for at least 24 h with deionized water and rinse several times prior to use. When conducting

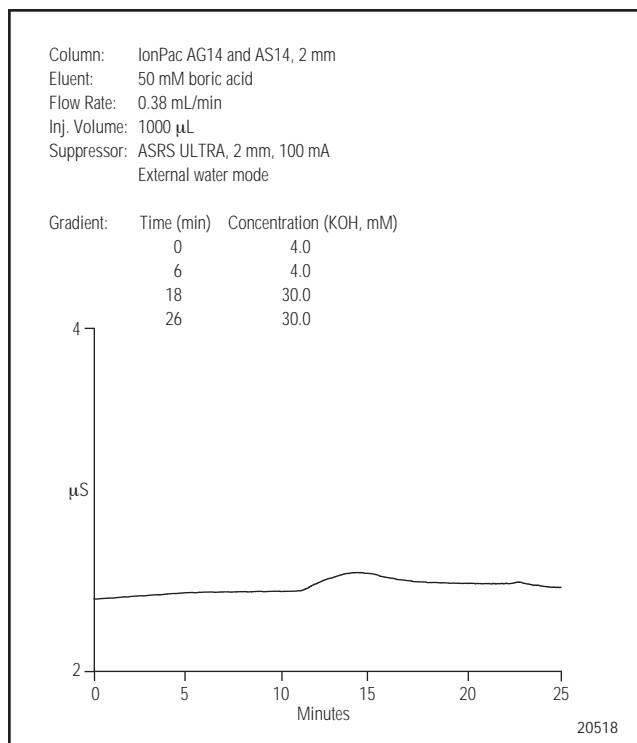

Figure 5. Representative system blank.

Table 3. MDLs for Determination of Trace Anions in Borated Waters Using Eluent Generation and Boric Acid Eluent

Anion	MDL, * $\mu\text{g/L}$
Fluoride	0.030
Chloride	0.053
Nitrate	0.10
Phosphate	0.32
Sulfate	0.090

\*Calculated based on three times signal-to-noise

analyses at trace levels, the sources of contamination are numerous. Wear vinyl disposable gloves when handling equipment that makes contact with eluent, standard, or samples. After putting on the gloves, rinse them with deionized water, then air dry. Do not dry with paper towels. All containers should be dedicated to this analysis and copiously rinsed with 18  $\text{M}\Omega\text{-cm}$  or better deionized water before use. Exercise caution when handling anything that could have contact with the blank, unknown, or standards. The flow path of the chromato-

graphic instrumentation (eluent containers, injector, pump, valves, tubing, columns, suppressor, and conductivity cell) is a potential source of contamination. Rinse with high-purity water to reduce residual contamination.

The ATC-HC should be periodically regenerated with the procedure described in the "System Preparation and Setup" section. Monitoring the blank for any significant increase in anionic contamination will indicate when regeneration is necessary. Monitoring the background conductivity will indicate when regeneration is necessary. A significant increase beyond 3  $\mu\text{S}$  indicates that the ATC-HC has exceeded its capacity to trap ionic contaminants and should be regenerated. The frequency of regeneration depends on the quality of the deionized water and usage rate of the instrument. Expect to regenerate the ATC-HC at least every 30 days of continuous (24/7) operation.

## REFERENCES

1. Electric Power Research Institute. *Corrosion Fatigue Boiler Failures in Waterwall Economizers*. EPRI TR-100455, Palo Alto, CA, April 1992; 6–24.
2. Ling, R.; Srinivasan, K.; Saini, S.; Pohl, C.; Avdalovic, N.; Presented at the International Ion Chromatography Symposium, San Diego, CA, September 2003; Poster A-15.
3. Liu, Y.; Kaiser, E.; Avdalovic, N. *Microchem J.* **1999**, 62, 162–173.

## SUPPLIERS

- Gelman Sciences, 600 S. Wagner Road, Ann Arbor, MI 48106-1448 USA, 1-800-521-1520, [www.pall.com/gelman](http://www.pall.com/gelman).
- J. T. Baker, 222 Red School Lane, Phillipsburg, NJ 08865 USA, Tel: 800-582-2537, [www.jtbaker.com](http://www.jtbaker.com).
- Nalge Nunc International, 75 Panorama Creek Drive, P.O. Box 20365, Rochester, NY 14625 USA, Tel: 1-800-625-4327, [www.nalgenunc.com](http://www.nalgenunc.com).

Acrodisk is a registered trademark of Gelman Sciences, Inc. ASRS, AutoSuppression, Chromeleon, EluGen, and IonPac are registered trademarks of Dionex Corporation.



**Dionex Corporation**  
1228 Titan Way  
P.O. Box 3603  
Sunnyvale, CA  
94088-3603  
(408) 737-0700

**Dionex Corporation**  
Salt Lake City Technical Center  
1515 West 2200 South, Suite A  
Salt Lake City, UT  
84119-1484  
(801) 972-9292

**Dionex U.S. Regional Offices**  
Sunnyvale, CA (408) 737-8522  
Westmont, IL (630) 789-3660  
Houston, TX (281) 847-5652  
Atlanta, GA (770) 432-8100  
Marlton, NJ (856) 596-06009

**Dionex International Subsidiaries**  
*Australia* 61 (2) 9420 5233 *Austria* (01) 616 51 25 *Belgium* (03) 353 42 94 *Canada* (905) 844-9650 *China* (852) 2428 3282  
*France* 01 39 30 01 10 *Germany* 06126-991-0 *Italy* (06) 66 51 50 52 *Japan* (06) 6885-1213 *Korea* 82 2 2653 2580  
*The Netherlands* (0161) 43 43 03 *Switzerland* (062) 205 99 66 *United Kingdom* (01276) 691722  
\* Designed, developed, and manufactured under an NSAI registered ISO 9001 Quality System.

