

# Determination of Cr(VI) in Water, Waste Water, and Solid Waste Extracts

## INTRODUCTION

Chromium, while not unique in its properties, is commonly used in various industries because of the characteristics of the metal and its compounds. The predominant use of chromium in industry unfortunately introduces an environmental concern. Chromium exists almost exclusively in the Cr(III) oxidation state or in the Cr(VI) oxidation state. In the environment Cr(III) is typically not a problem. The uncomplexed trivalent species is the chromic ion,  $\text{Cr}^{3+}$ , and while it is soluble in acidic solutions, it typically precipitates as the hydroxide in alkaline solutions. It shares the quality with all other metals of being toxic to biological systems at some level. Fortunately its relative toxicity is low. This is due to the slow ligand exchange kinetics of Cr(III), causing it to be fairly unreactive. Actually, Cr(III) is essential to mammalian systems, admittedly at low concentrations, for the maintenance of several metabolic pathways. In contrast, Cr(VI) seems to serve no useful biological purpose to living things.

The hexavalent species exists primarily as chromic acid ( $\text{H}_2\text{CrO}_4$ ) and its salts, hydrogen chromate ion ( $\text{HCrO}_4^-$ ) and chromate ion ( $\text{CrO}_4^{2-}$ ), depending on the pH. The predominant species present, as a function of the pH, are  $\text{H}_2\text{CrO}_4$  at pHs less than about 1,  $\text{HCrO}_4^-$  at pHs between 1 and 6, and  $\text{CrO}_4^{2-}$  at pHs above about 6 (see Figure 1). The dichromate ion ( $\text{Cr}_2\text{O}_7^{2-}$ ) is a dimer of  $\text{HCrO}_4^-$ , less a water molecule, which forms when the concentration of chromium exceeds approximately 1 g/L.

Cr(VI) is a strong oxidizer and therefore harmful in biological systems. This fact warrants its regulation in the environment. As is typical, the oxidizing power of Cr(VI) is a function of pH. As the pH becomes lower, Cr(VI) is more inclined to oxidize something. Fortu-

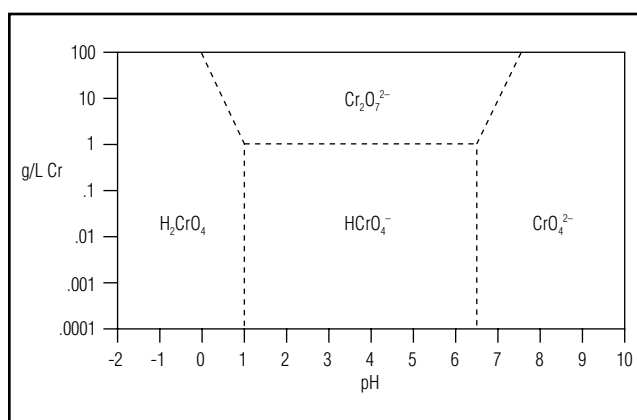

**Figure 1** Relative distribution of Cr(VI) species in water as a function of pH and Cr(VI) concentration.

nately, environmental samples are typically alkaline and, because the reduction potential of Cr(VI) decreases as the pH increases, Cr(VI) is less reactive at these higher pHs.

The contrast in qualities of Cr(III) and Cr(VI) has become the reason it is critical to differentiate between the two oxidation states when analyzing environmental or process samples. Various industries assert that environmental regulation efforts should be focused on Cr(VI) instead of on the relatively harmless Cr(III). This position has credence but, whether one wants or needs to determine one or both species in a sample, the analytical method must be capable of differentiating between the two. Speciation of various oxidation states of a metal in a sample is not always easy. Even after an analytical method has been developed, the question of whether or not the sample preparation procedure has altered the relative concentration of the species of interest still remains.

These issues combine to make a difficult analytical situation. To date, the study of sampling and sample preparation procedures for the speciation of chromium is an area of considerable activity. Existing sample preparation procedures (extraction, digestion, filtration) are undergoing critical review. They have proven to be imprecise, to be incomplete, and to alter the relative oxidation state concentrations.

The current trend is toward sample digestion and extraction procedures which give values for dissolved (free) Cr(VI) or total chromium as Cr(VI). Examples of these are the TCLP (Toxicity Characteristic Leaching Procedure) Extraction and Alkaline-Persulfate Digests, both of which generate high ionic strength matrices; not matrices of choice for most instrumental analytical methods.

Development of analytical methods is also ongoing, but the methods are dependent on the sample preparation procedures to determine the ultimate applicability of the techniques. Most spectroscopic and electrochemical methods are not specific enough. Because of these inadequacies, substantial sample work-up is required for useful analytical results.

The method presented in this Technical Note overcomes many analyte interference problems by separating the two chromium oxidation states and the other sample components and using a detection method specific for the Cr(VI) capable of handling the high ionic strength sample matrices generated in many leaching, impinging, and digestion procedures. This method is consistent with U.S. EPA method 218.6 and is described in several other publications<sup>2-5</sup>.

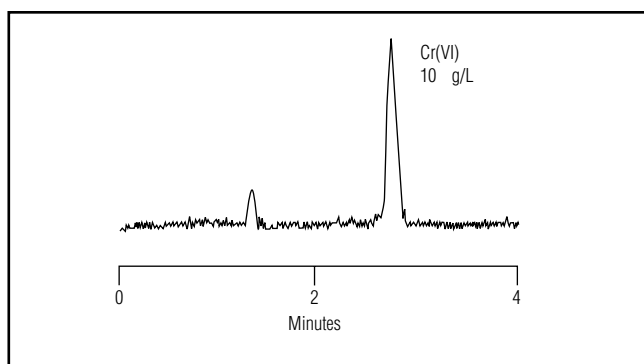
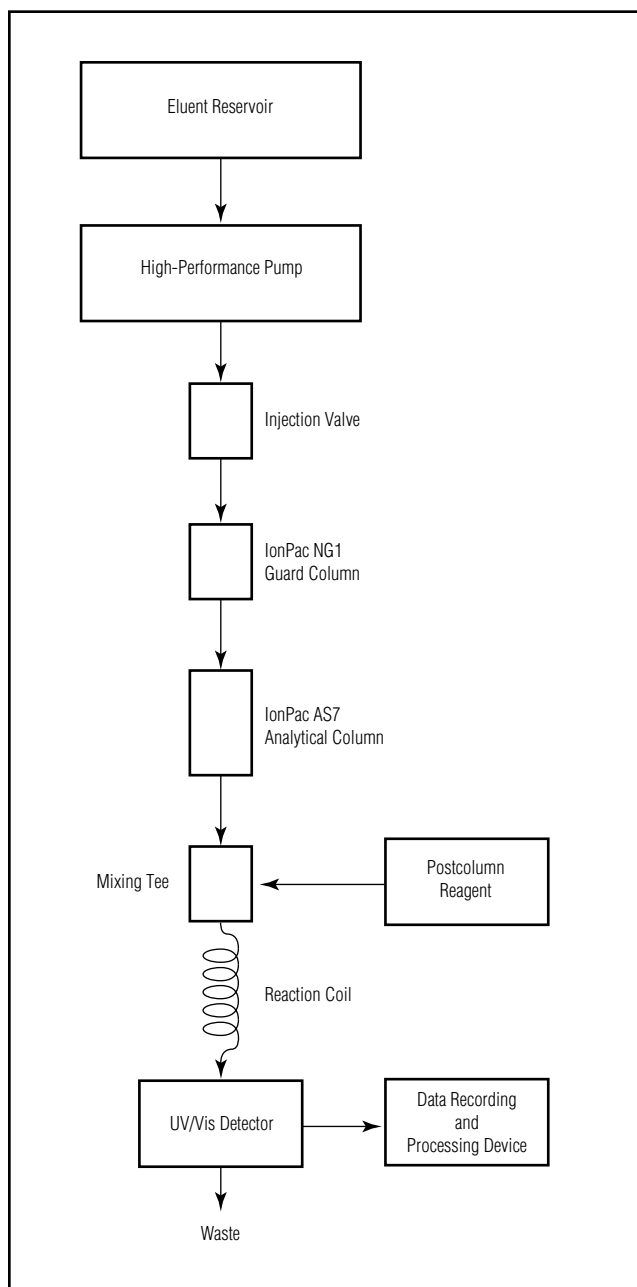

**Figure 2** Determination of Cr(VI) in water, waste water, and solid waste extracts.

## DISCUSSION OF METHOD

The method allows the detection of low- $\mu\text{g/L}$  levels of Cr(VI) in typical high ionic strength matrices. As discussed, most analysts are concerned with free Cr(VI) only, or total chromium as Cr(VI), so the method is specific for Cr(VI).

Using this method, hexavalent chromium is chromatographed as the divalent  $\text{CrO}_4^{2-}$  anion on the IonPac<sup>®</sup> AS7 column using a well-buffered ammonium sulfate, ammonium hydroxide eluent (see Figure 2). After the



**Figure 3** System flow diagram.

separation, Cr(VI) reacts with the color reagent diphenylcarbohydra-zide (DPC) in the following reaction:

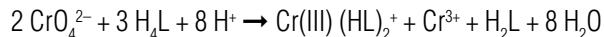

where:

$\text{H}_4\text{L}$  = diphenylcarbazide

$\text{H}_2\text{L}$  = diphenylcarbazone

The reaction is apparently the simultaneous oxidation of diphenylcarbazide to diphenylcarbazone, reduction of Cr(VI) to Cr(III), and the chelation of Cr(III) by diphenylcarbazone. The actual structure of the chelate is not known, but it is detected by visible absorbance using a photometric detector at 520 to 530 nm. A diagram of the system flow path is shown in Figure 3.

The analysis time is about 5 minutes. The method has a linear detection response from the detection limit,

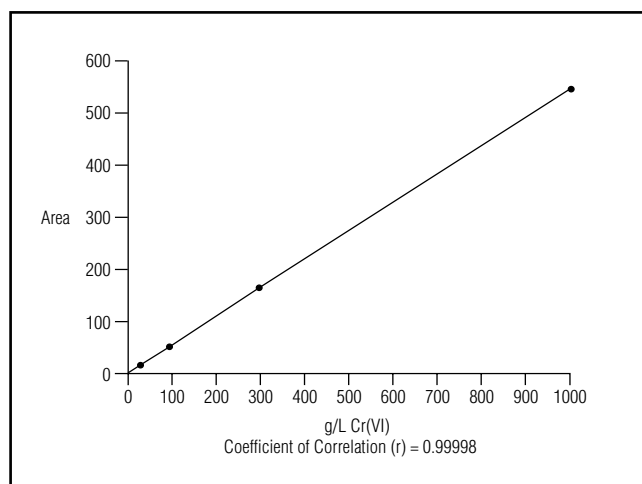

**Figure 4** Area response for colorimetric chromium detection.

### CONDITIONS

Guard Column: IonPac NG1  
 Analytical Column: IonPac AS7  
 Eluent: 250 mM Ammonium sulfate  
 100 mM Ammonium hydroxide  
 Eluent Flow Rate: 1.5 mL/min  
 Postcolumn Reagent: 2 mM DPC  
 10% Methanol, 1 N Sulfuric acid  
 Postcolumn Reagent  
 Flow Rate: 0.5 mL/min  
 Detection Wavelength: 520 nm  
 Sample Volume: 50–100  $\mu\text{L}$

which is about 50 pg or 1  $\mu\text{g/L}$  using a 50- $\mu\text{L}$  loop, up to around 0.5  $\mu\text{g}$  or 10 mg/L using a 50- $\mu\text{L}$  loop (Figure 4). Relative standard deviations from multiple injections of the same sample are 1% to 3% at concentrations above 10  $\mu\text{g/L}$ .

The method can handle samples of up to 5% sodium sulfate, 2% sodium chloride, 1 M acetate buffer, or 0.5 M carbonate buffer without adverse effects on the analysis. Figures 5A, 5B, and 5C illustrate the responses of 100- $\mu\text{g/L}$  Cr(VI) spikes in various concentrations of these sample matrices. Increasing the matrix ionic strength, as illustrated in Figure 6 for the acetate buffer, eventually causes column overload and compromises the chromatography and detection.

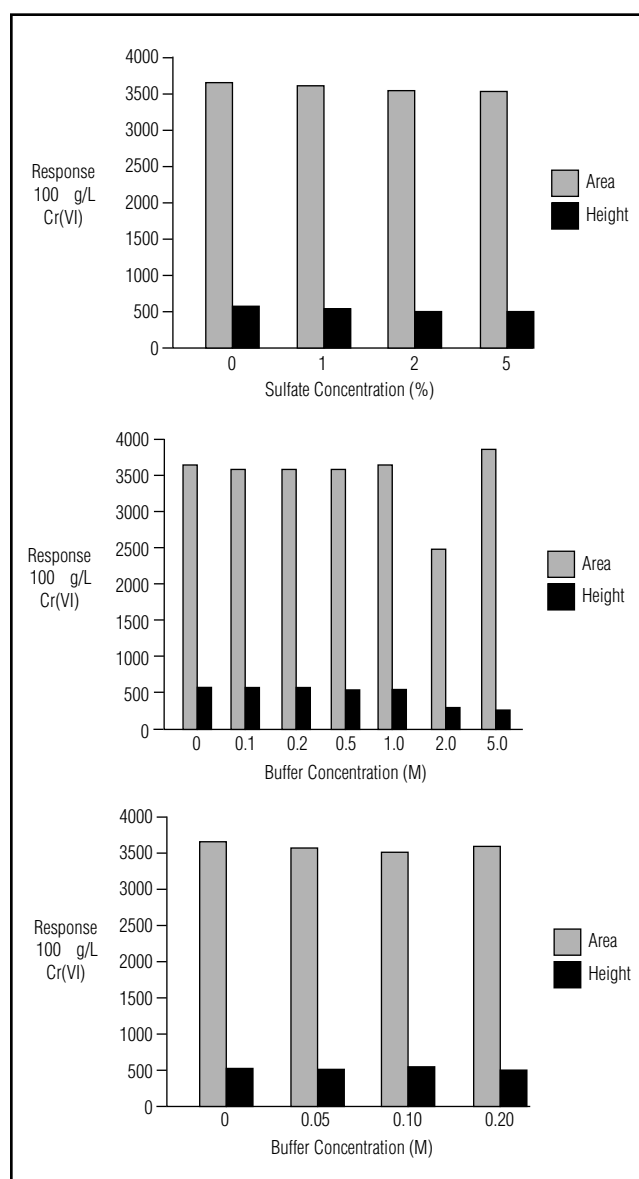

**Figure 5** A) Alkaline sulfate samples. B) Acetate buffer samples. C) Carbonate buffer samples.

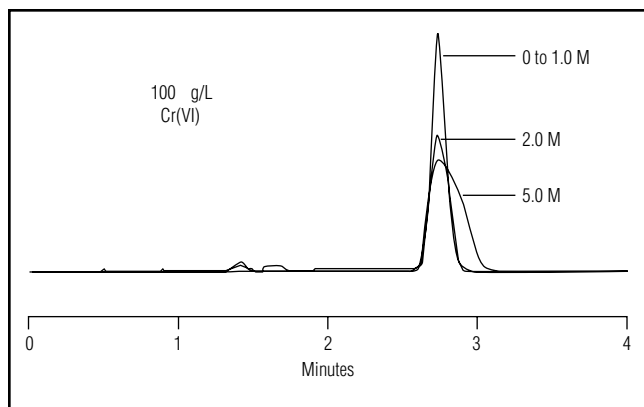

**Figure 6** Cr(VI) in acetate buffer.

### RECOMMENDED EQUIPMENT

DX-500 Chromatography System:

- GP40 Gradient Pump or IP20 Isocratic Pump
- AD20 Absorbance Detector
- PC10 Postcolumn Pneumatic Delivery Package
- OnGuard™-P Sample Pretreatment Cartridges

### REAGENTS AND STANDARDS

All reagents are analytical reagent grade or better.

- Deionized water, 18 MΩ-cm
- Sulfuric acid, 96%
- Methanol, HPLC grade
- Ammonium hydroxide, 29%
- Ammonium sulfate
- 1,5-Diphenylcarbohydrazide
- Potassium dichromate

### REAGENT PREPARATION

#### Eluent:

- 250 mM Ammonium sulfate
- 100 mM Ammonium hydroxide

Dissolve 33.0 g of ammonium sulfate in about 500 mL of water. Add 6.5 mL of 29% ammonium hydroxide. Mix well and dilute to 1.0 L in a volumetric flask. Transfer the solution to the eluent bottle. If you desire, you may multiply the weight and volumes listed for the eluent by an appropriate factor to prepare a larger volume of the eluent.

#### Postcolumn Reagent:

- 2.0 mM Diphenylcarbohydrazide
- 10% Methanol
- 1 N Sulfuric acid

Dissolve 0.5 g of 1,5-diphenylcarbohydrazide in 100 mL of HPLC-grade methanol. Add to about 500 mL of water containing 28 mL of 98% sulfuric acid. Dilute, with stirring, to 1.0 L in a volumetric flask. Transfer the solution to the pressurized reagent container. The solution is stable for several days but should only be prepared as it is used, one liter at a time.

### STANDARDS PREPARATION

#### Chromium Stock:

1000 ppm Cr(VI)

Dissolve 0.283 g of potassium dichromate ( $K_2Cr_2O_7$  dried at 100 °C for one hour) in water. Dilute to 100 mL in a volumetric flask.

#### Chromium Standard:

Standards are prepared by appropriate dilutions of the stock solution. As an example, for a 1-mg/L Cr(VI) standard, pipet 1.00 mL of the Chromium Stock solution into a 1.0 L volumetric flask. Dilute to volume with water.

### SAMPLE PREPARATION

Collect samples in amber glass bottles with plastic lined caps. Clean the bottles with 1:1  $HNO_3$  and rinse well with deionized water before use.

Because Cr(VI) is an oxidizer, care must be taken in sampling and sample preparation procedures. Sampling and preservation procedures often involve changing the sample pH, which may result in changes in the relative concentrations of the oxidation states.

Refrigeration of the samples, minimal sample handling, and immediate analysis is suggested as the best protocol for maintaining the integrity of the samples. After collecting the samples, store at 4 °C to minimize chemical reactivity. Analyze within 24 hours.

Analyze drinking water, rain water, and air particulate extract solutions directly with no sample preparation (other than possible dilution). Filter ground water and waste water samples through 0.45- $\mu$ m filters before injection.

Pass samples such as ground water, waste water, and solid waste extracts, which may contain high concentrations of organic contaminants, through OnGuard-P syringe cartridges before injection. This procedure is not absolute-ly necessary, but it helps prevent premature fouling of the column. Be sure to follow the instructions

---

for the use of the cartridges, which are enclosed with the cartridge package.

### **TROUBLESHOOTING**

This method is simple and rugged but this troubleshooting guide has been included to minimize any down time. The guide lists the symptoms of some of the problems you might experience as well as their likely causes and remedies.

If you continue to have any difficulties, please call your local Dionex Regional Office.

#### **Symptom: No peak observed**

- Possible Cause: No sample injected.
- Remedy: Ensure that the pressurized gas used to switch the injection valve is on.
- Remedy: Ensure that the sample is loaded from the autosampler or syringe.
  
- Possible Cause: Recording device not properly connected.
- Remedy: Check that the computer interface is turned on, or that the recording device is connected to the detector.
  
- Possible Cause: No postcolumn reagent flow.
- Remedy: Check that the flow rate out of the cell is 2.0 mL/min and that the backpressure past the mixing tee is less than 50 psi.
  
- Possible Cause: Wrong detector wavelength.  
Remedy: Check that the wavelength readout is 530 nm.

#### **Symptom: Noisy baseline**

- Possible Cause: Air bubble in cell.
- Remedy: Disconnect line cell inlet, replace with a luer-type adapter, and flush the cell with a few mL of methanol or isopropanol.

#### **Symptom: Low column pressure**

- Possible Cause: Air in pump head.
- Remedy: Prime the pump with eluent (see your pump instruction manual).
  
- Possible Cause: Leak in system.
- Remedy: Tighten or replace leaking fitting.

#### **Symptom: Excessive pressure on column**

- Possible Cause: Improper flow rate.
- Remedy: Check that the pump flow rate is 1.5 mL/min.
  
- Possible Cause: Fitting is plugged.
- Remedy: With the pump off, remove the columns and reconnect the eluent lines. Turn on the pump and check that the system pressure is less than 100 psi when the valve is in either the LOAD or INJECT position.
  
- Possible Cause: Column bed support plugged.
- Remedy: Replace the bed support on the column. See the column manual for instruction.

#### **Symptom: Peak response too high or too low**

- Possible Cause: Incorrect detector range (applies when using analog output only).
- Remedy: Check that the detector range is correct.
  
- Possible Cause: Incorrect sample loop size.
- Remedy: Ensure that the sample loop volume is 50  $\mu$ L or 100  $\mu$ L.
  
- Possible Cause: Low postcolumn reagent flow rate.
- Remedy: Check that the flow rate from the detector waste line is 2.0 mL/min.

---

**Symptom:****Poor peak shape — reasonable retention time**

- Possible Cause: Column is overloaded with a sample concentration that is too high.
- Remedy: Dilute the sample so that the peak response is below that expected for a 1- $\mu$ g injection.

**Symptom:****Poor peak shape — incorrect retention time**

- Possible Cause: The eluent was prepared incorrectly.
- Remedy: Prepare new eluent; the pH of the eluent should be approximately 8 to 9.
  
- Possible Cause: The column is contaminated with strongly retained anions, metals, or organics.
- Remedy: Pump acetonitrile through ONLY the NG1 guard column for about 30 minutes, and then rinse with deionized water for about 15 minutes. Pump 1 N HCl through all of the columns for one hour, rinse with deionized water for 30 minutes, and reequilibrate with eluent for 30 minutes.

**REFERENCES**

1. Arar, E.J.; Long, S.E.; Pfaff, J.D. "Method 218.6 Determination of Dissolved Hexavalent Chromium in Drinking Water, Groundwater, and Industrial Waste Water Effluents by Ion Chromatography", Nov. 1991, United States Environmental Protection Agency (U.S. EPA), Cincinnati, OH 45268.
2. Dionex Application Note 80, "Determination of Dissolved Hexavalent Chromium in Drinking Water, Groundwater, and Industrial Waste Water Effluents by Ion Chromatography".
3. Arar, E.J.; Pfaff, J.D. *J. Chromatogr. Sci.* **1991**, 546, 335–340.
4. ASTM Method D5257-93: "Dissolved Hexavalent Chromium in Water by Ion Chromatography", June 1991, American Society for Testing and Materials (ASTM), Committee D-19, Philadelphia, PA 19103.
5. Proposed ASTM Method: "Collection and Analysis of Hexavalent Chromium in the Atmosphere", Nov. 1991, ASTM, Committee D-22, Philadelphia, PA 19103.

OnGuard is a trademark and IonPac is a registered trademark of Dionex Corporation.



Printed on recycled and recyclable paper with soy-based inks.

---

**Dionex Corporation**  
1228 Titan Way  
P.O. Box 3603  
Sunnyvale, CA  
94088-3603  
(408) 737-0700

**Dionex Corporation**  
Salt Lake City Technical Center  
1515 West 2200 South, Suite A  
Salt Lake City, UT  
84119-1484  
(801) 972-9292

**Dionex U.S. Regional Offices**  
Sunnyvale, CA (408) 737-8522  
Westmont, IL (630) 789-3660  
Houston, TX (281) 847-5652  
Smyrna, GA (770) 432-8100  
Marlton, NJ (609) 596-0600

**Dionex International Subsidiaries**  
*Austria* (0222) 616 51 25 *Belgium* (015) 203800 *Canada* (905) 844-9650 *France* 01 39 46 08 40 *Germany* (06126) 991-0  
*Italy* (6) 66030052 *Japan* (06) 885-1213 *The Netherlands* (076) 57 14 800 *Switzerland* (062) 205 99 66 *United Kingdom* (01276) 691722  
\* Designed, developed, and manufactured under an NSAI registered ISO 9001 Quality System.  
<http://www.dionex.com>



LPN 034398-02 1M 1/98  
© 1998 Dionex Corporation